

MSG

MULTI-STAGE CENTRIFUGAL PUMPS

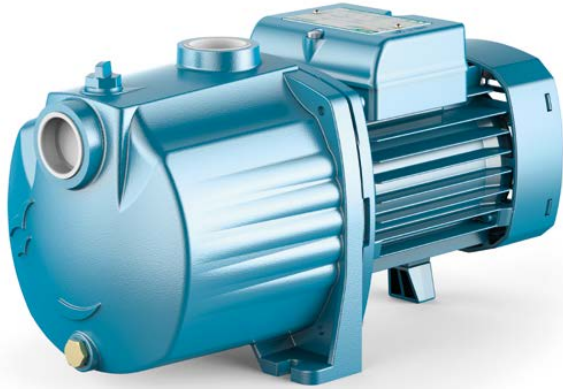

Clean water Domestic use



PERFORMANCE RANGE

- Flow rate up to **130 l/min** (7.8 m³/h)
- Head up to **52 m**

APPLICATION LIMITS

- Manometric suction lift up to **7 m**
- Liquid temperature between **-10 °C** and **+40 °C**
- Ambient temperature up to **+40 °C**
- Max. working pressure **6 bar**
- Continuous service **S1**

CONSTRUCTION AND SAFETY STANDARDS

EN 60335-1
IEC 60335-1
CEI 61-150

EN 60034-1
IEC 60034-1
CEI 2-3



CHARACTERISTIC CURVES AND PERFORMANCE DATA

50 Hz | n = 2900 min⁻¹ | HS = 0 m

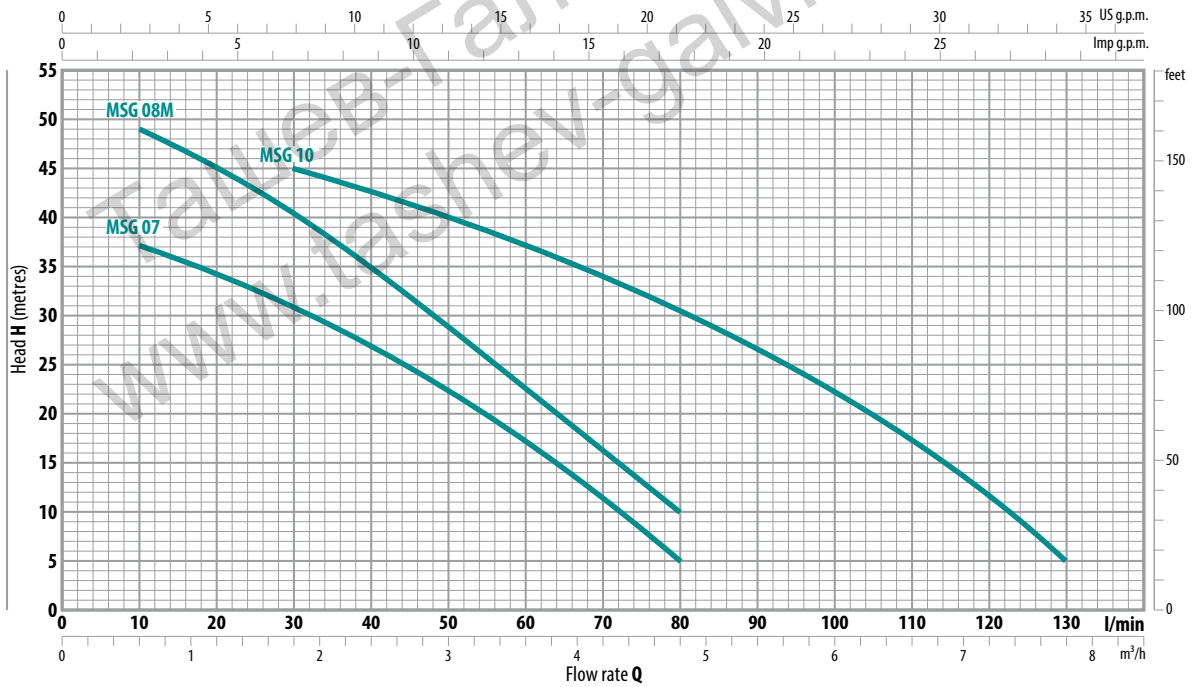

MODEL		POWER (P ₂)		Q	Flow rate																	
Single-phase	Three-phase	kW	HP		m ³ /h	0	0.3	0.6	0.9	1.2	1.5	1.8	2.4	3.0	3.6	4.2	4.8	5.4	6.0	7.2	7.8	
				l/min	0	5	10	15	20	25	30	40	50	60	70	80	90	100	120	130		
MSG 07M	MSG 07	0.45	0.60	H metres	40	38	37	36	34.5	33	31	27	22.5	17	11	5						
MSG 08M	MSG 08	0.55	0.75		52	50	49	47	44.5	42	40	34	28.5	22.5	16	10						
MSG 10M	MSG 10	0.75	1		50	50	49	48	47	46	45	42	39.5	37	34	30.5	26.5	22	11	5		

Q = Flow rate
H = Total manometric head
HS = Suction height

Tolerance of characteristic curves in compliance with EN ISO 9906 Grade 3B.

INSTALLATION AND USE

Suitable for use with clean water and with liquids that are not chemically aggressive towards the materials from which the pump is made. As a result of their quietness, these pumps are widely used in domestic applications such as the distribution of water in combination with small and medium sized pressure tanks, and for the irrigation of gardens and orchards, etc.

The pump should be installed in an enclosed environment or sheltered from inclement weather.

CONSTRUCTION CHARACTERISTICS

PUMP BODY	Cast iron with an Epoxy Electro Coating treatment, with threaded ports in compliance with ISO 228/1
IMPELLERS	Noryl FE1520PW
MOTOR SHAFT	Stainless steel EN 10088-3 - 1.4104
MECHANICAL SEAL	Ceramic - Graphite - NBR
ELECTRIC MOTOR	The three-phase pumps are fitted with high performance motors up to P2=0.55kW in class IE2 and from P2=0.75kW in class IE3 (IEC 60034-30)

DIMENSIONS AND WEIGHT

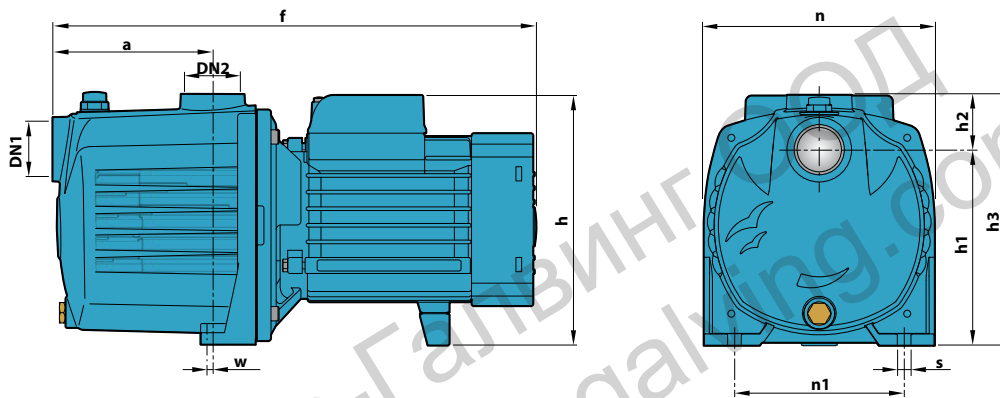

MODEL		PORTS		DIMENSIONS mm										kg	
Single-phase	Three-phase	DN1	DN2	a	f	h	h1	h2	h3	n	n1	w	s	1~	3~
MSG 07M	MSG 07	1"	1"	110	332	172	134	38	172	158	116	1.5	9	10.0	10.0
MSG 08M	MSG 08					191 *								10.8	10.2
MSG 10M	MSG 10					191 *								13.4	13.4

(*) h=210 mm for single phase versions at 110 V

ABSORPTION

MODEL	VOLTAGE		
	Single-phase	230 V	240 V
MSG 07M	3.4 A	3.3 A	6.8 A
MSG 08M	4.1 A	4.0 A	8.2 A
MSG 10M	6.0 A	5.8 A	12.0 A

MODEL	VOLTAGE					
	Three-phase	230 V	400 V	690 V	240 V	415 V
MSG 07	2.5 A	1.5 A	0.9 A	2.4 A	1.4 A	0.8 A
MSG 08	3.4 A	2.0 A	1.2 A	3.3 A	1.9 A	1.1 A
MSG 10	4.5 A	2.6 A	1.5 A	4.3 A	2.5 A	1.4 A

PALLETIZATION

MODEL		GROUPAGE	CONTAINER
Single-phase	Three-phase	n. pumps	n. pumps
MSG 07M	MSG 07	98	140
MSG 08M	MSG 08	98	140
MSG 10M	MSG 10	84	108